

EN 1-3

FR 4-6

ES 7-9

PT 10-12



# World One

## Assembly Instructions

North America: +1 800 400 0625  
Europe: +353 (0)1 858 0910  
Asia Pacific: +852 2581 0570

Humanscale®

## HARDWARE INCLUDED



Pin

(Needed Per Mount - 2)

---

## TOOLS REQUIRED FOR ASSEMBLY



Mallet

---

### STEP 1:

Install the gas cylinder into the 5 star base.  
Then install the seat assembly onto the gas cylinder.

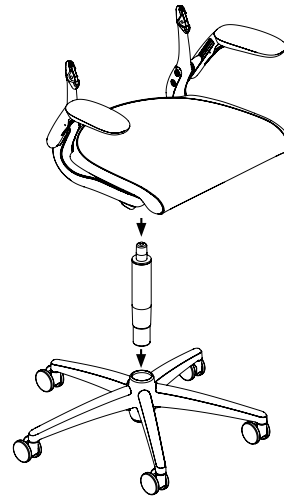

### STEP 2:

\*Do not remove the preinstalled foam spring from the chair frame.  
Install the back frame onto the seat frame using the 2 pins.  
Gently tap the pins using a mallet to securely seat the pins.

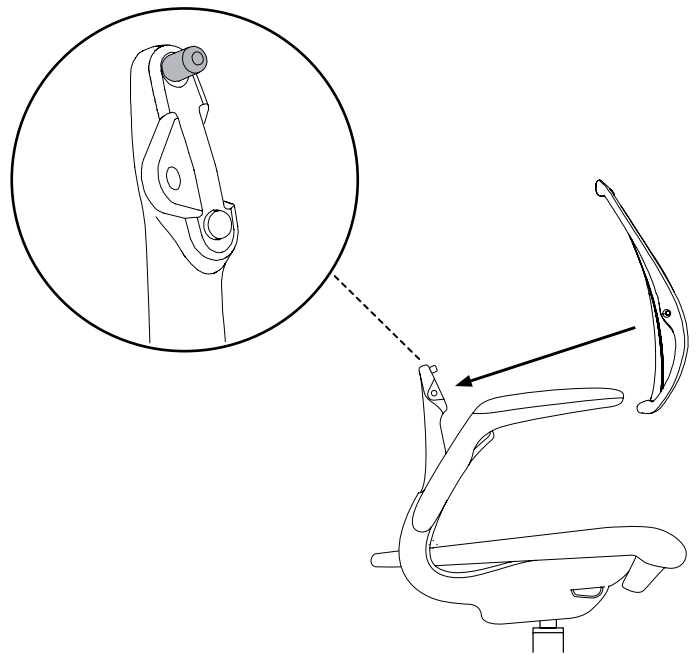
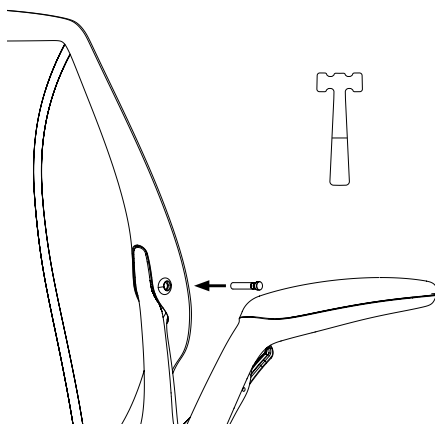

# CHAIR SPECIFICATIONS

Size	Width	25.75in (654mm)
	Depth	25in (635mm)
	Height	35.63in- 40.75in (905 - 1035mm)
	Seat Height	15.63in- 20.75in (397- 527mm)

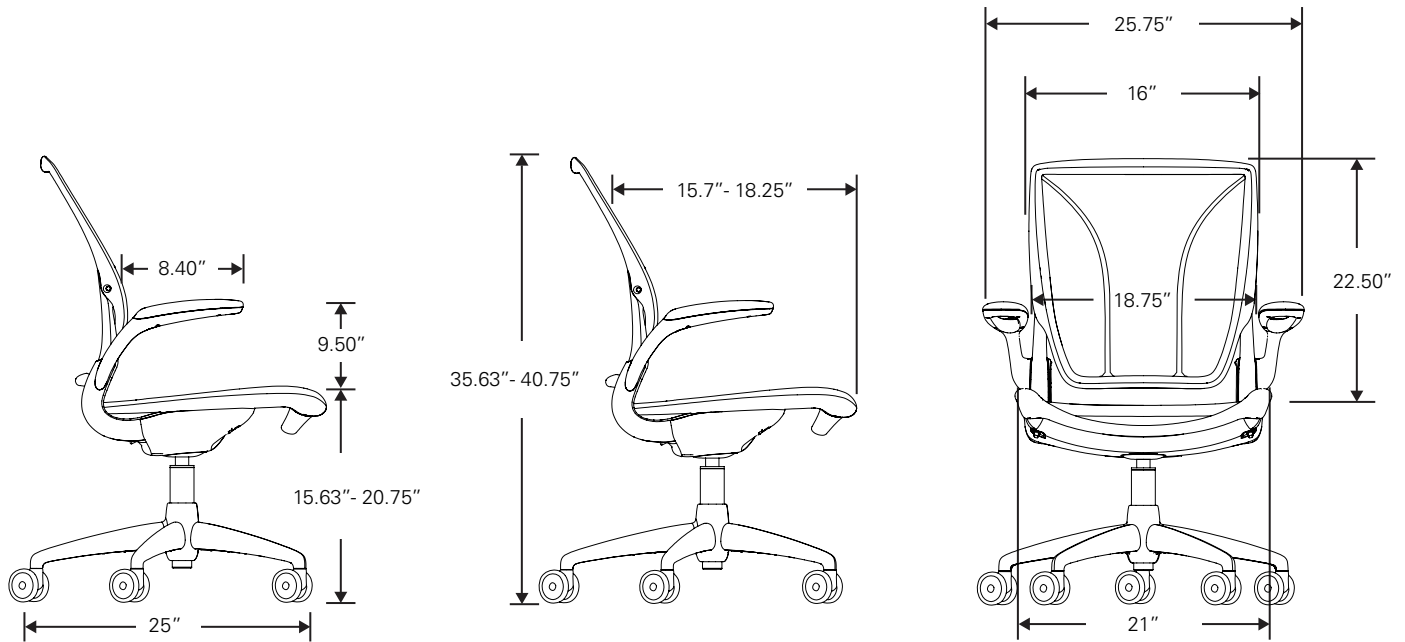

## CLEANING GUIDELINES

- Please use mild soap (i.e. Ivory Liquid Soap) and water.
- Gently wipe with a soft cloth to remove dirt and stains.
- Dry gently with a dry soft cloth.

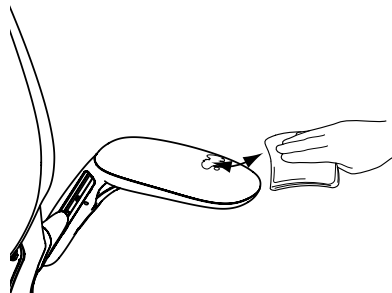
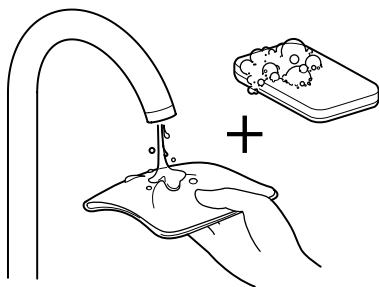

For a complete cleaning instruction, please refer to the [Seating Cleaning Instructions](http://www.humanscale.com/resources/download-library/manuals-installation-maintenance.cfm) found at [www.humanscale.com/resources/download-library/manuals-installation-maintenance.cfm](http://www.humanscale.com/resources/download-library/manuals-installation-maintenance.cfm)

For our terms and conditions please go to <https://www.humanscale.com/about/legal-information/terms-conditions.cfm>

© 2021 Humanscale Corporation. The text and artwork are copyrighted materials. All rights reserved. The Humanscale mark and logo are trademarks of Humanscale Corporation and are registered in the United States and certain other countries.



# World One

## Instructions d'assemblage

Amérique du Nord : +1 800 400-0625  
Europe : + 353 (0)1 858-0910  
Asie et Pacifique : + 852 2581-0570

Humanscale®

## MATÉRIEL INCLUS



Broche  
(2 nécessaires par support)

## OUTILS NÉCESSAIRES POUR LE MONTAGE



Maillet

### ÉTAPE 1 :

Insérez le vérin à gaz dans le piètement à 5 branches.  
Installez ensuite l'assise sur le vérin à gaz.

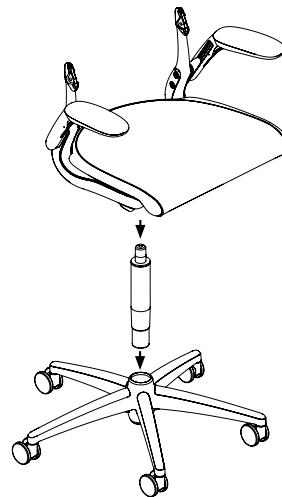

### ÉTAPE 2 :

\* Ne retirez pas le ressort en mousse préinstallé du cadre du fauteuil.  
Installez le cadre du dossier sur le cadre du siège à l'aide des 2 broches.  
Tapez doucement sur les broches à l'aide du maillet pour bien les fixer.

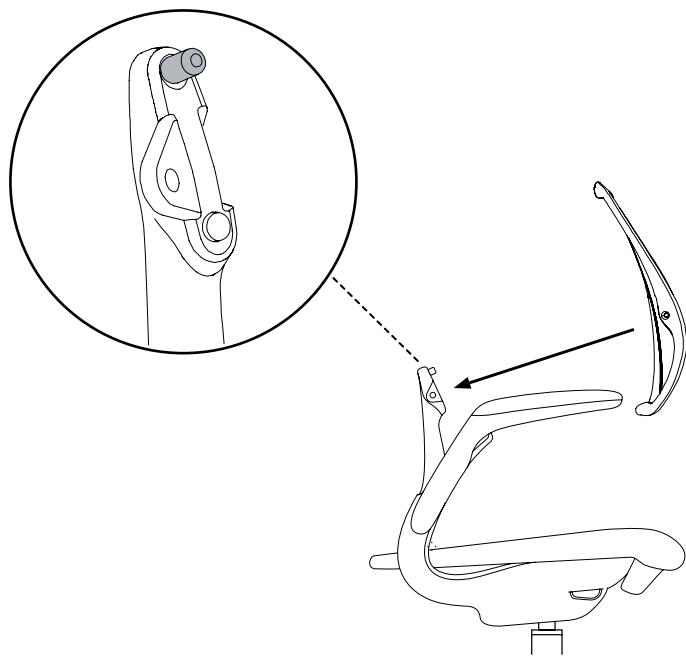
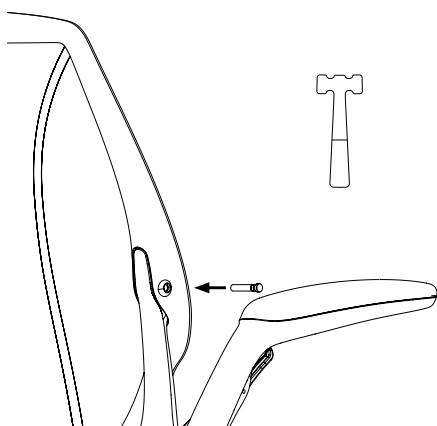

# CARACTÉRISTIQUES DU FAUTEUIL

Taille	Largeur	25,75 po (654 mm)
	Profondeur	25 po (635 mm)
	Hauteur	37 à 41,8 po (940 à 1061 mm)
	Hauteur du siège	16,4 po à 21,8 po (416 à 554 mm)

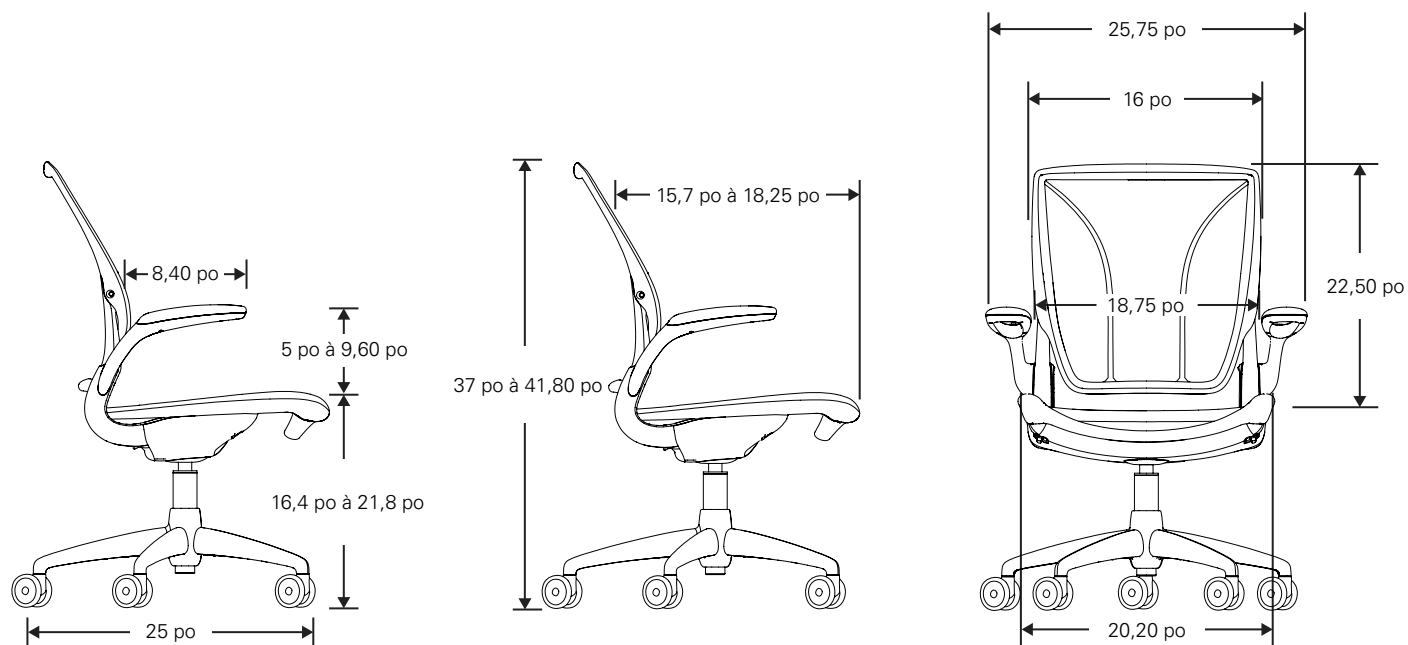

## INSTRUCTIONS DE NETTOYAGE

- Utilisez un savon doux (par exemple, du liquide vaisselle) et de l'eau.
- Essuyez délicatement avec un chiffon doux pour enlever la saleté et les taches.
- Séchez délicatement à l'aide d'un chiffon doux et sec.

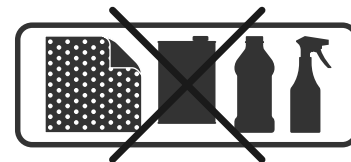
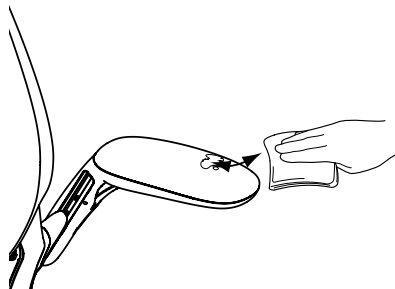
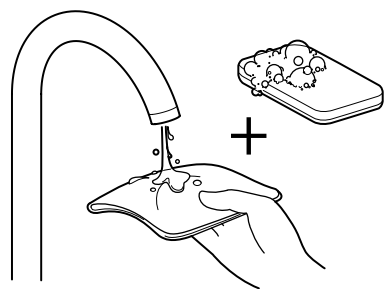

Pour une instruction complète de nettoyage, consultez la section [Instructions de nettoyage du siège](#) que vous trouverez à l'adresse [www.humanscale.com/resources/download-library/manuals-installation-maintenance.cfm](http://www.humanscale.com/resources/download-library/manuals-installation-maintenance.cfm)

Pour connaître nos conditions générales, consultez le site <https://www.humanscale.com/about/legal-information/terms-conditions.cfm>

© 2021 Humanscale Corporation. Le texte et les illustrations de ce document sont protégés par des droits d'auteur. Tous droits réservés. La marque ainsi que le logo de Humanscale sont des marques de commerce de Humanscale Corporation qui sont enregistrées aux États-Unis ainsi que dans certains autres pays.



# World One

Instrucciones de ensamblaje

Norteamérica: +1 800 400 0625  
Europa: +353 (0)1 858 0910  
Asia-Pacífico: +852 2581 0570

Humanscale®

## MATERIALES DE MONTAJE INCLUIDOS



Perno

(se necesitan 2 para el montaje)

---

## HERRAMIENTAS REQUERIDAS PARA EL ENSAMBLAJE



Mazo

---

### PASO 1:

Coloque el cilindro neumático en la base de 5 puntas.  
Luego, coloque el ensamblaje del asiento sobre el cilindro neumático.

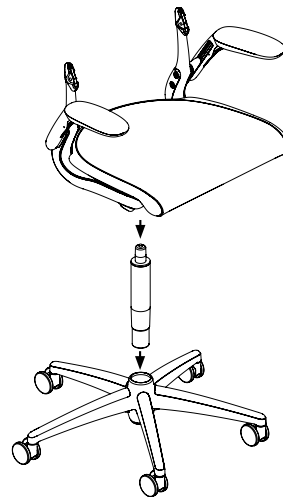

---

### PASO 2:

\* No extraiga el muelle de gomaespuma que viene colocado en el armazón de la silla.  
Coloque el armazón del respaldo sobre el armazón del asiento usando los 2 pernos.  
Golpee suavemente los pernos con el mazo para fijarlos adecuadamente.

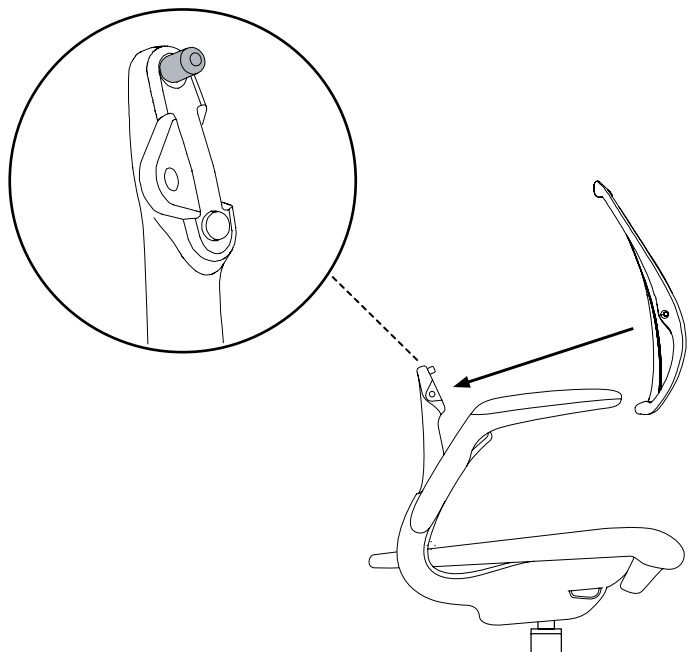
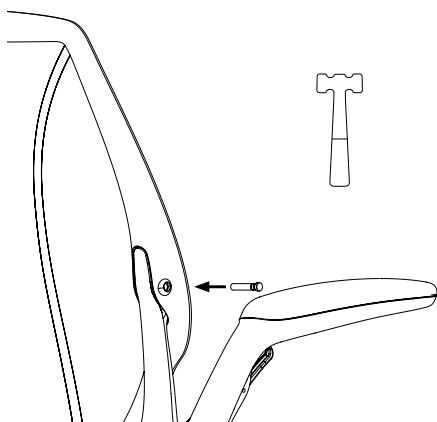



# ESPECIFICACIONES DE LA SILLA

Tamaño	Ancho	25,75 in (654 mm)
	Profundidad	25 in (635 mm)
	Altura	De 37 a 41,8 in (de 940 a 1061 mm)
	Altura del asiento	De 16,4 a 21,8 in (de 416 a 554 mm)

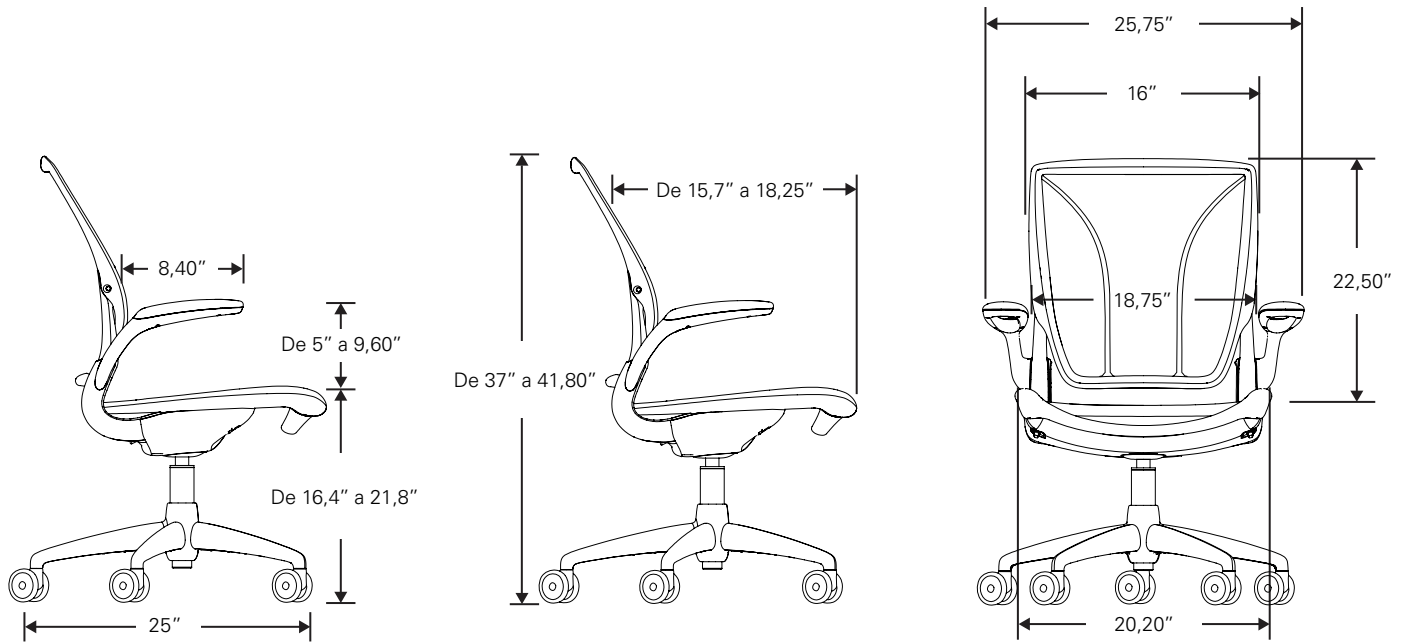

## PAUTAS DE LIMPIEZA

- Use agua y un jabón suave (por ejemplo, el jabón líquido Ivory).
- Pase un paño suave con cuidado para quitar la suciedad y las manchas.
- Seque cuidadosamente con un paño suave y seco.

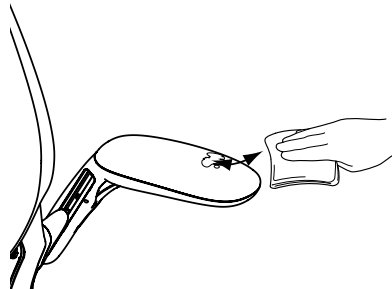
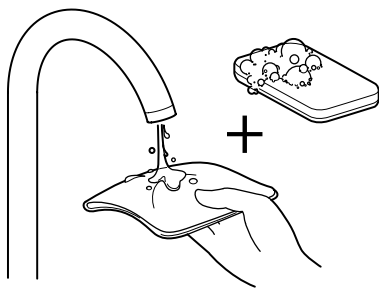

Si desea obtener instrucciones completas para la limpieza, consulte [Seating Cleaning Instructions](http://www.humanscale.com/resources/download-library/manuals-installation-maintenance.cfm) (Instrucciones de limpieza de sillas) en [www.humanscale.com/resources/download-library/manuals-installation-maintenance.cfm](http://www.humanscale.com/resources/download-library/manuals-installation-maintenance.cfm).

Para consultar los términos y condiciones, visite <https://www.humanscale.com/about/legal-information/terms-conditions.cfm>

© 2021 Humanscale Corporation. El texto y las imágenes son materiales con derechos de autor. Todos los derechos reservados. La marca y el logotipo de Humanscale son marcas comerciales de Humanscale Corporation y están registradas en los Estados Unidos y en otros países.



# World One

Instruções de montagem

América do Norte: +1 800 400 0625  
Europa: +353 (0)1 858 0910  
Ásia-Pacífico: +852 2581 0570

Humanscale®

## HARDWARE INCLUSO



Pino

(Necessário para montar - 2)

## FERRAMENTAS NECESSÁRIAS PARA A MONTAGEM



Martelo

### PASSO 1:

Instale o cilindro de gás na base de 5 pontas.  
Em seguida, instale o conjunto do assento sobre o cilindro de gás.

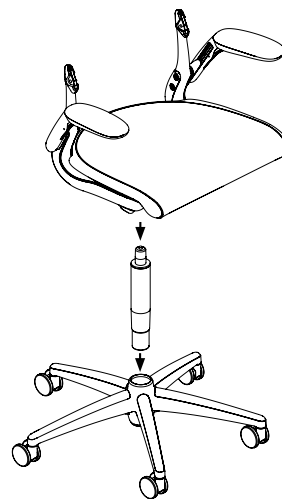

### PASSO 2:

\*Não remova a espuma pré-instalada da estrutura da cadeira.  
Instale o encosto traseiro na estrutura do assento usando os 2 pinos.  
Bata suavemente nos pinos usando um martelo para assentar os pinos com segurança.

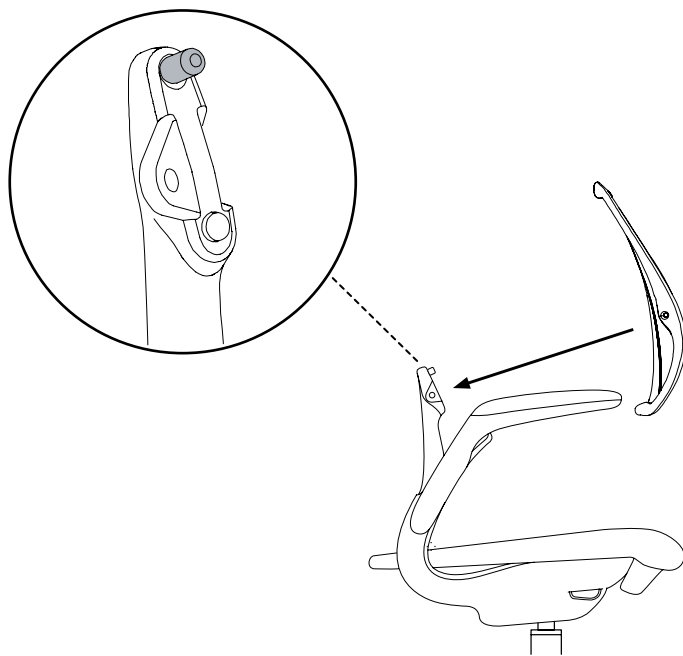
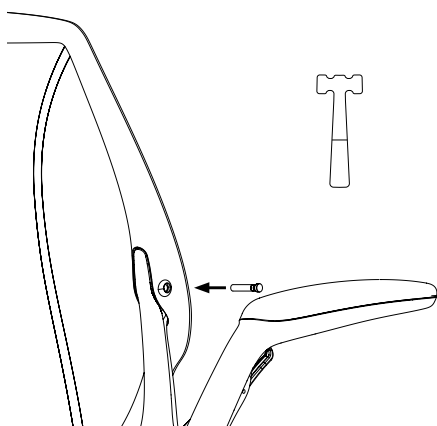

# ESPECIFICAÇÕES DA CADEIRA

Tamanho	Largura	25.75 in (654 mm)
	Comprimento	25 in (635 mm)
	Altura	37 in- 41.8 in (940- 1061 mm)
	Altura do assento	16.4 in- 21.8 in (416- 554 mm)

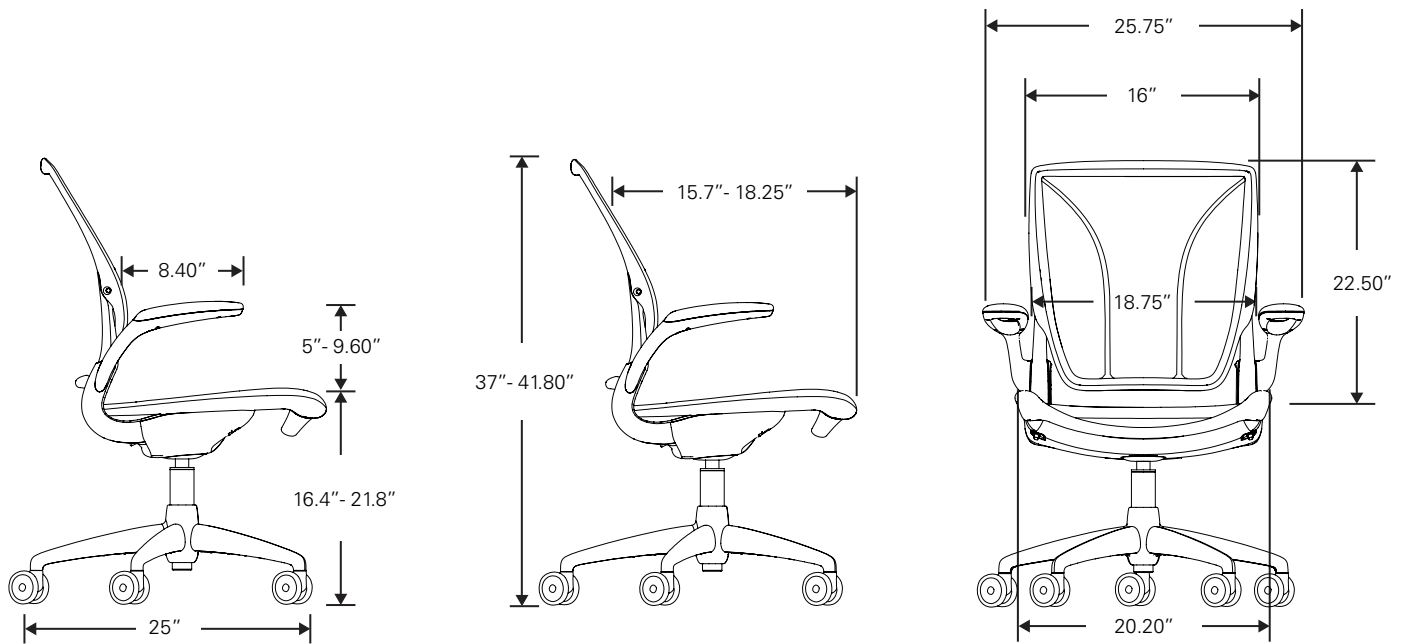

## ORIENTAÇÕES PARA LIMPEZA

- Use sabão suave (ou seja, sabonete líquido neutro) e água.
- Limpe suavemente com um pano macio para remover sujeira e manchas.
- Seque suavemente com um pano seco e macio.

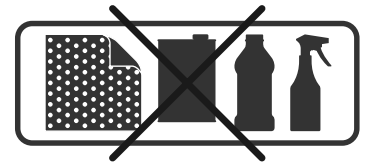
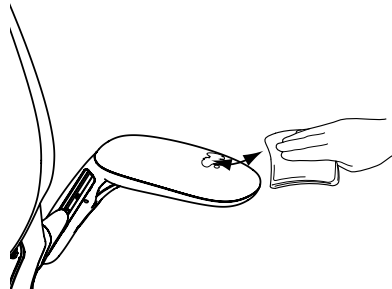
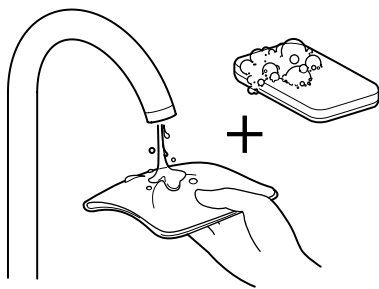

Para instrução completa de limpeza, consulte as [Instruções de limpeza de assentos](http://www.humanscale.com/resources/download-library/manuals-installation-maintenance.cfm) encontradas em [www.humanscale.com/resources/download-library/manuals-installation-maintenance.cfm](http://www.humanscale.com/resources/download-library/manuals-installation-maintenance.cfm)

Para ler nossos termos e condições, visite <https://www.humanscale.com/about/legal-information/terms-conditions.cfm>

© 2021 Humanscale Corporation. O texto e as ilustrações são materiais protegidos por direitos autorais. Todos os direitos reservados. A marca e o logotipo da Humanscale são marcas comerciais da Humanscale Corporation e estão registrados nos Estados Unidos e em outros países.

humanscale.com